

Introduction

As the demand for high frequency applications increases, RF components such as mixers and filters play a critical role in most RF system design. The vector mixer calibration method allows for measurement of mixer transmission complex S-parameters including phase and group delay of the transmission coefficient. The vector mixer calibration method ensures a matching frequency at both test ports of the analyzer, in normal operation mode. The vector mixer calibration procedure will be outlined in this app note.

Vector Mixer Calibration

The vector mixer measurements require an additional mixer with filter, which is called calibration mixer. The filter separates the IF, which is the input frequency for the mixer under test:

- RF + LO
- RF – LO
- LO – RF

Both calibration mixer and mixer under test are powered from one LO. The vector mixer measurement is a combination of a 2-port calibration and a de-embedding function (See Figure 1).

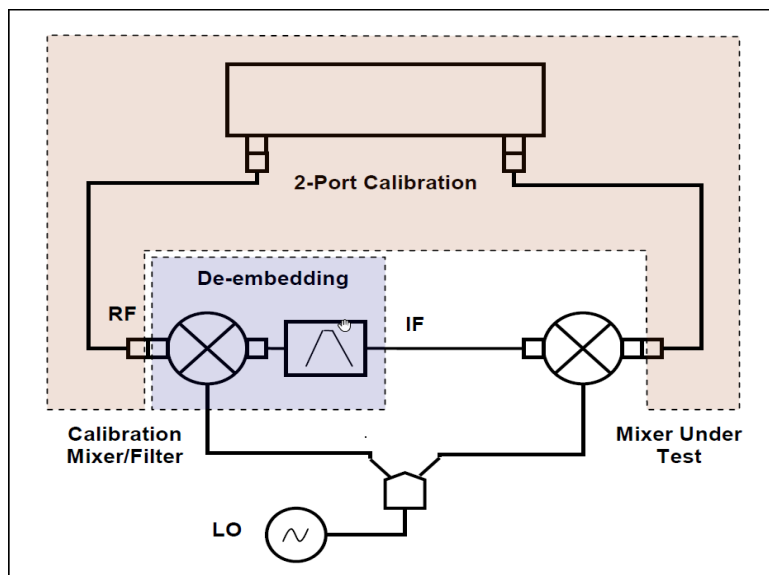

Figure 1: Vector Mixer Measurements

The de-embedding function requires an S-parameter file of the circuit. Acquisition of such a file for the calibration mixer/filter pair is called vector mixer calibration.

To obtain an S-parameter file of the calibration mixer/filter, you need to use SHORT, OPEN, and LOAD calibration standards (See Figure 2).

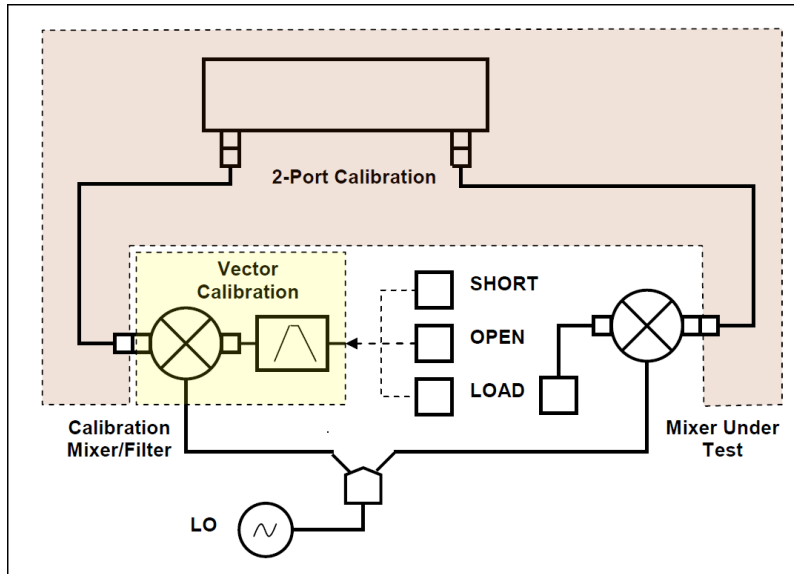

Figure 2: Vector Mixer Calibration

Vector Mixer Calibration Procedure

Before you start the calibration, perform the following settings: activate a channel and set its parameters (frequency span, IF bandwidth, etc.), and define the calibration kit.

- Perform 2-port calibration.
- Assemble vector calibration setup.
- Set frequency and power of the external LO.



To access the vector mixer calibration menu, use the following softkeys:

Calibration > Mixer/Converter Calibration > Vector Mixer Calibration

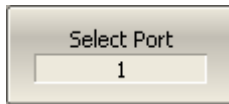

To select the number of test port connected to the calibration mixer, click **Select Port**.

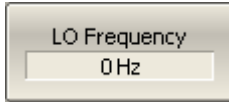

Enter the LO frequency, using **LO Frequency** softkey.

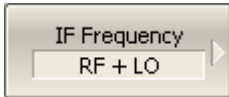

Select the frequency to be separated by the filter, using **IF Frequency** softkey:

- RF + LO
- RF – LO
- LO – RF

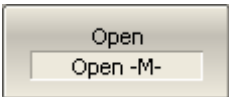

To complete the calibration procedure, click **Save To Touchstone File**.

This will activate calculation of the calibration mixer/filter pair S-parameters, and saving those into a Touchstone file. Enter the file name in the pop-up dialog.

If **Setup Option** feature is enabled, S-parameter file will be passed to the de-embedding function and this function will be activated.

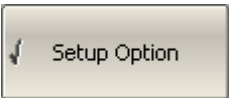

To complete the calibration procedure, click **Save To Touchstone File**.



This will activate calculation of the calibration mixer/filter pair S-parameters, and saving those into a Touchstone file. Enter the file name in the pop-up dialog.

If **Setup Option** feature is enabled, S-parameter file will be passed to the de-embedding function and this function will be activated.

Note:

You can check the calibration status in channel status bar (See Table 20) – **F2** and **Dmb** labels (2-port calibration and de-embedding function).

Conclusion

Mixers are an important component in the design of RF receivers and transmitters. To get the most out of the design it is important to carefully measure the operating characteristics of the device. This app note should help you get started with your vector mixer measurements. If you need further clarification on this application note or any assistance with your application, please contact:

support@coppermountaintech.com.

